

LICENSING SUB COMMITTEE

Tuesday, 29 October 2019 at 6.30 p.m.

The Council Chamber, Town Hall, Mulberry Place, 5 Clove Crescent,
London, E14 2BG

SUPPLEMENTAL AGENDA 2

This meeting is open to the public to attend.

Contact for further enquiries:

Simmi Yesmin, Senior Democratic Services Officer
1st Floor, Town Hall, Mulberry Place, 5 Clove Crescent, E14 2BG
Tel: 020 7364 4120
E-mail: simmi.yesmin@towerhamlets.gov.uk
Web: <http://www.towerhamlets.gov.uk/committee>

Scan this code for
the electronic
agenda:



For further information, see the main agenda.

	PAGE NUMBER(S)	WARD(S) AFFECTED
4 .2 Licensing Act 2003 Application for variation of a Premises Licence for The Old George Public House, 379 Bethnal Green Road, London, E2 0AN	3 - 16	St Peter's
4 .4 Licensing Act 2003 Temporary Event Notice for Hurk, Unit 8, 29 Whitepost Lane, London E9 5EN	17 - 52	Bow East

This page is intentionally left blank

From: Kathy Driver
Sent: 22 October 2019 16:22
To: Luke Wilson; Farhana Zia
Subject: FW: Old George Public House, 379 Bethnal Green Road, London - Premises Licence Hearing 29th October 2019 GTE:00214000000166
Attachments: Amended Conditions - Old George .docx
Follow Up Flag: Follow up
Flag Status: Flagged

This has just come through so see attached conditions.
This will need to be added.

Kind Regards,

Kathy Driver
Principal Licensing Officer

Licensing Team
John Onslow House
1 Ewart Place
London
E3 5EQ

Please note:
Meetings with Licensing Officers are by prearranged appointment only.

Tel: 020 7364 5171
Fax: 020 7364 0863
Hotline: 0207 364 5008

General email: licensing@towerhamlets.gov.uk

Please visit our web page for application forms and guidance
at www.towerhamlets.gov.uk/licensing



From: Lavine Miller-Johnson
Sent: 22 October 2019 16:07
To: [REDACTED]
Cc: Nicola Cadzow; Kathy Driver
Subject: FW: Old George Public House, 379 Bethnal Green Road, London - Premises Licence Hearing 29th October 2019 GTE:00214000000166

Dear [REDACTED]

Sorry for the delay, I have been off sick and returned today.

Based on the list of amended conditions you have attached, I am happy for these to be added to the licence. I therefore withdraw my representations.

Kind Regards

Lavine Miller-Johnson

Licensing & Safety Team | Environmental Health and Trading Standards
London Borough of Tower Hamlets | John Onslow House, 1 Ewart Place, London E3 5EQ
☎ 020 7364 2665 | 📠 020 7364 6901 | General Enquiries: 020 7364 5008

From: [REDACTED]
Sent: 18 October 2019 14:26
To: Lavine Miller-Johnson; Nicola Cadzow
Subject: RE: Old George Public House, 379 Bethnal Green Road, London - Premises Licence Hearing 29th October 2019 GTE:0021400000166

Dear Lavine and Nicola,

I write further to the email below. I have slightly changed the list of agreed conditions so that it is absolutely clear that the external bar servery will close by 2100.

I attach an amended list of conditions which include all of those which we have agreed with you.

I would be grateful if you could confirm that this list does indeed include everything that you require as I propose to present it to the licensing committee at the hearing.

Kind Regards,

[REDACTED]

Anti-fraud notice – please read carefully: **We will not change our bank details during the course of this matter.**
If, during the course of this matter, you receive an email or phone call purporting to be from Gosschalks informing you that our bank details have changed, it is likely to be an attempted fraud. If this happens, please report it immediately to our Cashiers Department on 01482 590203 who will verify our bank details and, if necessary, report the matter to the police.

From: [REDACTED]
Sent: 16 October 2019 12:19
To: Lavine.Miller-Johnson@towerhamlets.gov.uk; Nicola.Cadzow@towerhamlets.gov.uk
Subject: Old George Public House, 379 Bethnal Green Road, London - Premises Licence Hearing 29th October 2019 GTE:0021400000166

Dear Lavine and Nicola,

I hope this email finds you both well. I have started to prepare for the hearing in a fortnight and had a little difficulty reconciling the conditions that we had agreed with each of you. For example, we had agreed with Nicola that the garden area would close at 2100 but then agreed a condition sought by Lavine that patrons permitted to temporary leave and re enter the premises should be limited in the external courtyard up to 10 persons after 2100.

In the circumstances, and for the sake of consistency, I have put together a single list of conditions which are the conditions that we have agreed with Lavine (where I have changed references to the external courtyard to references to the outside drinking area shown on the plan of the premises) and added a couple of conditions to reflect our agreement with Nicola that the outside area closes at 9pm.

I would be grateful if you could confirm that the attached composite list of conditions is satisfactory. On the basis that it is, then I will forward it to the licensing department to indicate that you are happy with these conditions.

I thank you for all of your help and assistance.

Kind Regards,

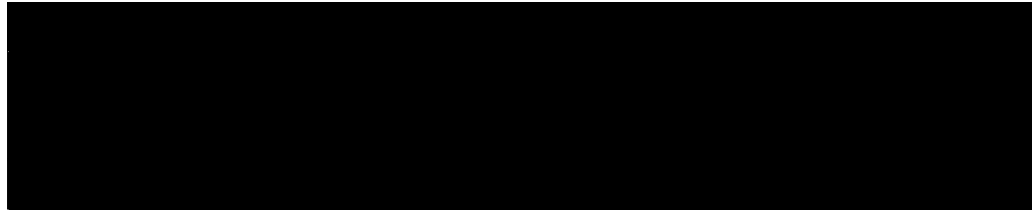

Anti-fraud notice – please read carefully: **We will not change our bank details during the course of this matter.** If, during the course of this matter, you receive an email or phone call purporting to be from Gosschalks informing you that our bank details have changed, it is likely to be an attempted fraud. If this happens, please report it immediately to our Cashiers Department on 01482 590203 who will verify our bank details and, if necessary, report the matter to the police.

IMPORTANT - PRIVACY NOTICE

In receiving this email, your personal data may have been saved to our internal systems. We value your privacy and data security, and if you would like to know how we manage your personal data, please read our full Privacy Statement here: <https://www.gosschalks.co.uk/legal/privacy-policy>

GOSSCHALKS DISCLAIMER: This is a PRIVATE communication. It is confidential, and may be legally privileged. All data transmitted in this message is intended for the sole use of the named addressee. If you are not a named addressee, you must not disclose, copy, print, or in any other way use or rely on the data contained in this transmission. You should notify Gosschalks immediately and dispose of this message.

In the case of email, although Gosschalks routinely checks emails for computer viruses, addressees are advised to conduct their own virus checks of all emails (and any attachments). All email sent to and from Gosschalks is scanned for viruses by MessageLabs.

Please note that Internet is not a completely secure communications medium, and this fact should be observed when corresponding with Gosschalks. To ensure regulatory compliance and to secure protection for our clients and business, emails sent to and from our server(s) may be monitored.

A list of the partners of Gosschalks is available for inspection at Queens Gardens, Hull, HU1 3DZ. Tel:01482 324252. For more information on Gosschalks, please visit our web site: www.gosschalks.co.uk - Gosschalks is authorised and regulated by the Solicitors Regulation Authority under number 61213.

Composite list of conditions incorporating those required by Nicola Cadzow (EHO) and Lavine Miller Johnson (EHO)

1. Loudspeakers shall not be located in the entrance lobby or outside the premise building.
2. All windows and external doors shall be kept closed when regulated entertainment takes place, except for the immediate access & egress of persons.
3. Notices shall be prominently displayed at all exits requesting patrons to respect the needs of local residents and businesses and leave the area quietly.
4. The external bar servery will close by 2100.
5. The outside drinking area/external courtyard shown on the plan attached to the premises licence will close to all patrons (save for a maximum of 10 smokers) at 2100.
6. No drinks will be permitted in the external courtyard/outside drinking area after 2100.
7. Patrons permitted to temporarily leave and then re-enter the premises, shall be limited in the external courtyard to up to 10 persons after 21:00 hours.
8. No noise shall emanate from the premises nor vibration be transmitted through the structure of the premises, which gives rise to a nuisance.
9. A direct telephone number for the manager at the premises shall be publicly available at all times the premises are open. The telephone number is to be made available to residents and businesses in the vicinity.

[REDACTED]

From: [REDACTED]
Sent: 23 October 2019 11:28
To: Nicola Cadzow
Cc: Licensing; Farhana Zia; Simmi Yesmin; Mandy Mighty; Lavine Miller-Johnson; Clare Johnson
Subject: Re: 118874 Old George Public House, 379 Bethnal Green Road, London

Hi Nicola

Thanks so much for that.

Kind regards

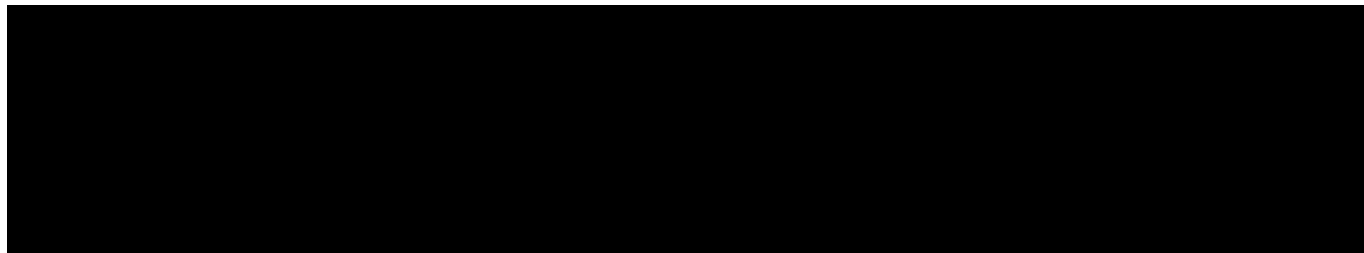

On 23 Oct 2019, at 11:18, Nicola Cadzow <Nicola.Cadzow@towerhamlets.gov.uk> wrote:

Dear Licensing,

I have discussed and corresponded with the client's representative. They have provided additional noise conditions as well as a noise management plan (both attached to this email), to include reduction of the use of the external area to 21:00. Based on the additional information provided Environmental Protection are satisfied that the applicant is showing how they will promote the licensing objective for the prevention of public nuisance, and therefore please take this as my withdrawing my representation.

Kind regards

Nicola Cadzow
Environmental Protection
Environmental Health Technical Officer
Place Directorate
Public Realm, Environmental Health & Trading Standards
London Borough of Tower Hamlets, John Onslow House, 1 Ewart Place, London E3 5EQ

From: [REDACTED]
Sent: 22 October 2019 16:21
To: Nicola Cadzow
Cc: Mandy Mighty
Subject: FW: Old George Public House, 379 Bethnal Green Road, London - Premises Licence Hearing 29th October 2019 GTE:00214000000166

Hi Nicola

Thanks for the chat earlier.

I've just had a message from Lavine that she is happy with the proposed conditions and will withdraw her representation. Her email is below.

Please could you confirm that you are also happy with the composite list of conditions so that I can pass this on to my partner, Clare Johnson who will be dealing with this on my behalf.

Thanks for all of your help with this.

Kind regards

[REDACTED]

Anti-fraud notice – please read carefully: **We will not change our bank details during the course of this matter.** If, during the course of this matter, you receive an email or phone call purporting to be from Gosschalks informing you that our bank details have changed, it is likely to be an attempted fraud. If this happens, please report it immediately to our Cashiers Department on 01482 590203 who will verify our bank details and, if necessary, report the matter to the police.

From: [REDACTED]
Sent: 22 October 2019 16:14
To: Lavine Miller-Johnson <Lavine.Miller-Johnson@towerhamlets.gov.uk>
Cc: Nicola Cadzow <Nicola.Cadzow@towerhamlets.gov.uk>; Kathy Driver <Kathy.Driver@towerhamlets.gov.uk>; Mandy Mighty <Mandy_Mighty@gosschalks.co.uk>
Subject: RE: Old George Public House, 379 Bethnal Green Road, London - Premises Licence Hearing 29th October 2019 GTE:00214000000166

Hi Lavine

Thank you so much for that.

I'm sorry to hear that you've been off. I hope that you are better.

Kind regards

[REDACTED]

Anti-fraud notice – please read carefully: **We will not change our bank details during the course of this matter.** If, during the course of this matter, you receive an email or phone call purporting to be from Gosschalks informing you that our bank details have changed, it is likely to be an attempted fraud. If this happens, please report it immediately to our Cashiers Department on 01482 590203 who will verify our bank details and, if necessary, report the matter to the police.

From: Lavine Miller-Johnson <Lavine.Miller-Johnson@towerhamlets.gov.uk>
Sent: 22 October 2019 16:07
To: [REDACTED]
Cc: Nicola Cadzow <Nicola.Cadzow@towerhamlets.gov.uk>; Kathy Driver <Kathy.Driver@towerhamlets.gov.uk>
Subject: FW: Old George Public House, 379 Bethnal Green Road, London - Premises Licence Hearing 29th October 2019 GTE:00214000000166

Dear Richard,

Sorry for the delay, I have been off sick and returned today.

Based on the list of amended conditions you have attached, I am happy for these to be added to the licence. I therefore withdraw my representations.

Kind Regards

Lavine Miller-Johnson

Licensing & Safety Team | Environmental Health and Trading Standards
London Borough of Tower Hamlets | John Onslow House, 1 Ewart Place, London E3 5EQ
☎ 020 7364 2665 | 📠 020 7364 6901 | General Enquiries: 020 7364 5008

From: [REDACTED]
Sent: 18 October 2019 14:26
To: Lavine Miller-Johnson; Nicola Cadzow
Subject: RE: Old George Public House, 379 Bethnal Green Road, London - Premises Licence Hearing 29th October 2019 GTE:0021400000166

Dear Lavine and Nicola,

I write further to the email below. I have slightly changed the list of agreed conditions so that it is absolutely clear that the external bar servery will close by 2100.

I attach an amended list of conditions which include all of those which we have agreed with you.

I would be grateful if you could confirm that this list does indeed include everything that you require as I propose to present it to the licensing committee at the hearing.

Kind Regards,

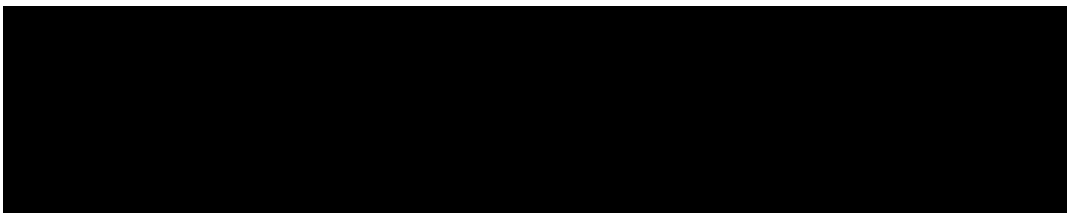

Anti-fraud notice – please read carefully: **We will not change our bank details during the course of this matter.** If, during the course of this matter, you receive an email or phone call purporting to be from Gosschalks informing you that our bank details have changed, it is likely to be an attempted fraud. If this happens, please report it immediately to our Cashiers Department on 01482 590203 who will verify our bank details and, if necessary, report the matter to the police.

From: [REDACTED]
Sent: 16 October 2019 12:19
To: Lavine.Miller-Johnson@towerhamlets.gov.uk; Nicola.Cadzow@towerhamlets.gov.uk
Subject: Old George Public House, 379 Bethnal Green Road, London - Premises Licence Hearing 29th October 2019 GTE:0021400000166

Dear Lavine and Nicola,

I hope this email finds you both well. I have started to prepare for the hearing in a fortnight and had a little difficulty reconciling the conditions that we had agreed with each of you. For example, we had agreed with Nicola that the garden area would close at 2100 but then agreed a condition sought

by Lavine that patrons permitted to temporary leave and re enter the premises should be limited in the external courtyard up to 10 persons after 2100.

In the circumstances, and for the sake of consistency, I have put together a single list of conditions which are the conditions that we have agreed with Lavine (where I have changed references to the external courtyard to references to the outside drinking area shown on the plan of the premises) and added a couple of conditions to reflect our agreement with Nicola that the outside area closes at 9pm.

I would be grateful if you could confirm that the attached composite list of conditions is satisfactory. On the basis that it is, then I will forward it to the licensing department to indicate that you are happy with these conditions.

I thank you for all of your help and assistance.

Kind Regards,

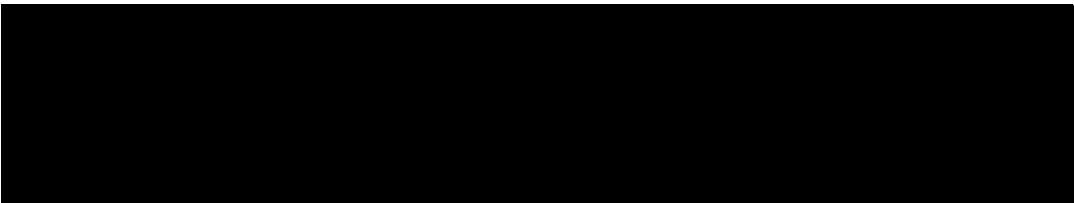

Anti-fraud notice – please read carefully: **We will not change our bank details during the course of this matter.** If, during the course of this matter, you receive an email or phone call purporting to be from Gosschalks informing you that our bank details have changed, it is likely to be an attempted fraud. If this happens, please report it immediately to our Cashiers Department on 01482 590203 who will verify our bank details and, if necessary, report the matter to the police.

IMPORTANT - PRIVACY NOTICE

In receiving this email, your personal data may have been saved to our internal systems. We value your privacy and data security, and if you would like to know how we manage your personal data, please read our full Privacy Statement here:
<https://www.gosschalks.co.uk/legal/privacy-policy>

GOSSCHALKS DISCLAIMER: This is a PRIVATE communication. It is confidential, and may be legally privileged. All data transmitted in this message is intended for the sole use of the named addressee. If you are not a named addressee, you must not disclose, copy, print, or in any other way use or rely on the data contained in this transmission. You should notify Gosschalks immediately and dispose of this message.

In the case of email, although Gosschalks routinely checks emails for computer viruses, addressees are advised to conduct their own virus checks of all emails (and any attachments). All email sent to and from Gosschalks is scanned for viruses by MessageLabs.

Please note that Internet is not a completely secure communications medium, and this fact should be observed when corresponding with Gosschalks. To ensure regulatory compliance and to secure protection for our clients and business, emails sent to and from our server(s) may be monitored.

A list of the partners of Gosschalks is available for inspection at Queens Gardens, Hull, HU1 3DZ. Tel:01482 324252. For more information on Gosschalks, please visit our web site:

www.gosschalks.co.uk - Gosschalks is authorised and regulated by the Solicitors Regulation Authority under number 61213.

IMPORTANT - PRIVACY NOTICE

In receiving this email, your personal data may have been saved to our internal systems. We value your privacy and data security, and if you would like to know how we manage your personal data, please read our full Privacy Statement here:
<https://www.gosschalks.co.uk/legal/privacy-policy>

GOSSCHALKS DISCLAIMER: This is a PRIVATE communication. It is confidential, and may be legally privileged. All data transmitted in this message is intended for the sole use of the named addressee. If you are not a named addressee, you must not disclose, copy, print, or in any other way use or rely on the data contained in this transmission. You should notify Gosschalks immediately and dispose of this message.

In the case of email, although Gosschalks routinely checks emails for computer viruses, addressees are advised to conduct their own virus checks of all emails (and any attachments). All email sent to and from Gosschalks is scanned for viruses by MessageLabs.

Please note that Internet is not a completely secure communications medium, and this fact should be observed when corresponding with Gosschalks. To ensure regulatory compliance and to secure protection for our clients and business, emails sent to and from our server(s) may be monitored.

A list of the partners of Gosschalks is available for inspection at Queens Gardens, Hull, HU1 3DZ. Tel:01482 324252. For more information on Gosschalks, please visit our web site: www.gosschalks.co.uk - Gosschalks is authorised and regulated by the Solicitors Regulation Authority under number 61213.

<Noise Management policy Old George.docx>
<Amended Conditions - Old George_.docx>

IMPORTANT - PRIVACY NOTICE

In receiving this email, your personal data may have been saved to our internal systems. We value your privacy and data security, and if you would like to know how we manage your personal data, please read our full Privacy Statement here: <https://www.gosschalks.co.uk/legal/privacy-policy>

GOSSCHALKS DISCLAIMER: This is a PRIVATE communication. It is confidential, and may be legally privileged. All data transmitted in this message is intended for the sole use of the named addressee. If you are not a named addressee, you must not disclose, copy, print, or in any other way use or rely on the data contained in this transmission. You should notify Gosschalks immediately and dispose of this message.

In the case of email, although Gosschalks routinely checks emails for computer viruses, addressees are advised to conduct their own virus checks of all emails (and any attachments). All email sent to and from Gosschalks is scanned for viruses by MessageLabs.

Please note that Internet is not a completely secure communications medium, and this fact should be observed when corresponding with Gosschalks. To ensure regulatory compliance and to secure protection for our clients and business, emails sent to and from our server(s) may be monitored.

A list of the partners of Gosschalks is available for inspection at Queens Gardens, Hull, HU1 3DZ. Tel:01482 324252. For more information on Gosschalks, please visit our web site: www.gosschalks.co.uk - Gosschalks is authorised and regulated by the Solicitors Regulation Authority under number 61213.

Composite list of conditions incorporating those required by Nicola Cadzow (EHO) and Lavine Miller Johnson (EHO)

1. Loudspeakers shall not be located in the entrance lobby or outside the premise building.
2. All windows and external doors shall be kept closed when regulated entertainment takes place, except for the immediate access & egress of persons.
3. Notices shall be prominently displayed at all exits requesting patrons to respect the needs of local residents and businesses and leave the area quietly.
4. The external bar servery will close by 2100.
5. The outside drinking area/external courtyard shown on the plan attached to the premises licence will close to all patrons (save for a maximum of 10 smokers) at 2100.
6. No drinks will be permitted in the external courtyard/outside drinking area after 2100.
7. Patrons permitted to temporarily leave and then re-enter the premises, shall be limited in the external courtyard to up to 10 persons after 21:00 hours.
8. No noise shall emanate from the premises nor vibration be transmitted through the structure of the premises, which gives rise to a nuisance.
9. A direct telephone number for the manager at the premises shall be publicly available at all times the premises are open. The telephone number is to be made available to residents and businesses in the vicinity.

This page is intentionally left blank

Agenda Item 4.4

Committee : Licensing Sub Committee	Date 29/10/2019	Classification Unclassified	Report No.	Agenda Item No.
-----------------------------------------------	--------------------	---------------------------------------	------------	-----------------

Report of David Tolley Head of Environmental Health & Trading Standards Originating Officer: Kathy Driver Principal Licensing Officer	Title: Licensing Act 2003 Temporary Event Notice for Hurk, Unit 8, 29 Whitepost Lane, London E9 5EN Ward affected: Bow East
---------------------------------------------------------------------------------------------------------------------------------------------------------------------------------------	--------------------------------------------------------------------------------------------------------------------------------------------------

1.0 Summary

Applicant: Carl Edlund

Address of Premises: Unit 8, 29 Whitepost Lane
London E9 5EN

Objectors: Environmental Protection

2.0 Recommendations

2.1 That the Licensing Committee considers the application and objections then adjudicates accordingly.

LOCAL GOVERNMENT 2000 (Section 97) LIST OF "BACKGROUND PAPERS" USED IN THE DRAFTING OF THIS REPORT

Brief description of "background paper"	Tick if copy supplied for register	If not supplied, name and telephone number of holder
Licensing Act 2003 Section 182 Guidance Licensing Policy File Only		Kathy Driver 020 7364 5171

3.0 **Background**

- 3.1 This is an application for a Standard Temporary Event Notice.
- 3.2 Enclosed is a copy of the application. (**See Appendix 1**).
- 3.3 The applicant has described the nature of the application as follows:
Sale of alcohol and Regulated Entertainment for Halloween event.
- 3.4 The premises that has been applied for is:
Unit 8,29 Whitepost Lane, London E9 5EN
Includes Coffee Shop, Bar and courtyard which incorporates a further bar.

DJs will be playing recorded music on the Friday from 7pm (normal start time for the resident DJs) until 2am (finish time on this TEN for the Friday); then from 6pm - 4am in HWK Bar on the Saturday night / Sunday morning and 9pm - 1am in HWK coffee shop on the Saturday night / Sunday morning.

- 3.5 The dates/timings that have been applied for are as follows:
Saturday 2nd November 2019 midnight to 02:00 hours
Sunday 3rd November 2019 midnight until 04:00 hours
- 3.6 A map showing the relevant premises and immediate area is included as **Appendix 2**.

4.0 **Premises Licence**

- 4.1 The venue holds a premises licence. Members can impose one or more conditions of the existing licence on the TEN (in so far as such conditions are not inconsistent with the event) if it considers that this is appropriate for the promotion of the licensing objectives. A copy of the licence is attached in **Appendix 3**.

5.0 **Temporary Event Notices**

- 5.1 Temporary Event Notices (TENs) are a creation of the Licensing Act 2003. They provide a method by which licensable activities can be carried out on a temporary basis (max. 168 hrs) without a licence. The maximum number that can attend at any one time is 499. At least 10 full working days notice must be given to the licensing authority. When a TEN cannot be obtained, for example the event is over 499, then a full premises licence must be obtained, for a limited duration.

- 5.2 The licensing authority cannot oppose an application, (nor can local residents or businesses. The licensing authority must reject any application that does not meet the rules as to numbers, maximum per year etc. The limits are now as follows: 15 TEN per calendar year or 21 days. The responsible authorities that can object is the Metropolitan Police or Environmental Protection.
- 5.3 The Police and Environmental Protection can object on the grounds that allowing the event to go ahead will undermine one of the Licensing Objectives.
- 5.4 Following an objection by the relevant responsible authority one or more conditions may be imposed by the Licensing Authority
- (a) if it considers it appropriate for the promotion of the licensing objectives to do so,
 - (b) the conditions are also imposed on a premises licence or club premises certificate that has effect in respect of the same premises, or any part of the same premises, as the temporary event notice, and
 - (c) the conditions would not be inconsistent with the carrying out of the licensable activities under the temporary event notice.
- 5.5 Where the authority decides to impose one or more conditions;
- (a) the authority must give the premises user notice of the decision;
 - (b) the notice must be accompanied by a separate statement (the “statement of conditions”) which sets out the conditions that have been imposed on the temporary event notice; and
 - (c) a copy of the notice and statement of conditions must be given to each relevant party.
- 5.6 LATE TENs have been created through the Police Reform and Social Responsibilities Act 2011, a Late TEN can be made no later than FIVE working days and no earlier than NINE working days before the event. The limits to these applications are no more than 2 for a non personal licence holder or no more than 10 for a personal licence holder.
- 5.7 The Police and Environmental Protection can object to Late TENs, if an objection is made the Licensing Authority must issue a counter notice advising the event cannot take place.
- 6.0 **Objections**
- 6.1 Environmental Protection objections are contained in **Appendix 4**.

7.0 Advice to Members

- 7.1 The Police Reform and Social Responsibility Act 2011 amended legislation whereby Environmental Protection alongside Police can object to Temporary Event Notice under any of the licensing objectives.
- 7.2 This hearing is required by the Licensing Act 2003. As always the decision is on the civil burden of proof, i.e. the balance of probability.
- 7.3 Members can consider any of the licensing objectives. Other matters can also be dealt with elsewhere by primary legislation.
- 7.4 Premises users are not required to be on the premises for the entire duration of the event authorised by the TEN, but they will remain liable to prosecution for certain offences that may be committed at the premises during the period covered by it. These include, for example, the offences of the sale of alcohol to a person who is drunk; persistently selling alcohol to children; and allowing disorderly conduct on licensed premises.
- 7.5 The police or local authority exercising environmental health functions may contact the premises user to discuss their objections and try to come to an agreement which will allow the proposed licensable activities to proceed. The TEN can be modified. If there is no agreement, the licensing authority must hold a hearing to consider the notice.

8.0 Legal Comments

- 8.1 The Council's legal officer will give advice at the hearing.

9.0 Finance Comments

- 9.1 There are no financial implications in this report.

10.0 Appendices

Appendix 1	A copy of the application
Appendix 2	Maps of the area
Appendix 3	Premises Licence
Appendix 4	Environmental Protection objection

Appendix 1

Section 1 of 9

You can save the form at any time and resume it later. You do not need to be logged in when you resume.

System reference This is the unique reference for this application generated by the system.

Your reference You can put what you want here to help you track applications if you make lots of them. It is passed to the authority.

Are you an agent acting on behalf of the applicant? Put "no" if you are applying on your own behalf or on behalf of a business you own or work for.

Yes No

Applicant Details

* First name

* Family name

* E-mail

Main telephone number Include country code.

Other telephone number

Indicate here if you would prefer not to be contacted by telephone

Are you:

Applying as a business or organisation, including as a sole trader

Applying as an individual

A sole trader is a business owned by one person without any special legal structure. Applying as an individual means you are applying so you can be employed, or for some other personal reason, such as following a hobby.

Applicant Business

Is your business registered in the UK with Companies House? Yes No

Registration number

Business name If your business is registered, use its registered name.

VAT number Put "none" if you are not registered for VAT.

Legal status

Note: completing the Applicant Business section is optional in this form.

Continued from previous page...

Your position in the business

Home country

The country where the headquarters of your business is located.

Registered Address

Address registered with Companies House.

Building number or name

Street

District

City or town

County or administrative area

Postcode

Country

Section 2 of 9

APPLICATION DETAILS ([See also guidance on completing the form, general notes and note 1](#))

Have you had any previous or maiden names?

- Yes No

* Your date of birth

Applicant must be 18 years of age or older

National Insurance number

This box need not be completed if you are an individual not liable to pay UK national insurance.

Place of birth

Correspondence Address

Is the address the same as (or similar to) the address given in section one?

- Yes No

If "Yes" is selected you can re-use the details from section one, or amend them as required. Select "No" to enter a completely new set of details.

Building number or name

Street

District

City or town

County or administrative area

Postcode

Country

Continued from previous page...

Additional Contact Details

Are the contact details the same as (or similar to) those given in section one?

If "Yes" is selected you can re-use the details from section one, or amend them as required. Select "No" to enter a completely new set of details.

Yes No

E-mail

Telephone number

Other telephone number

Section 3 of 9

THE PREMISES

I, the proposed user, hereby give notice under section 100 of the Licensing Act 2003 of my proposal to carry out a temporary activity at the premises described below.

Give the address of the premises where you intend to carry on the licensable activities or if it has no address give a detailed description (including the Ordnance Survey references). [\(See also guidance on completing the form, note 2\)](#)

* Does the premises have an address?

Yes No

Address

Is the address the same as (or similar to) the address given in section one?

If "Yes" is selected you can re-use the details from section one, or amend them as required. Select "No" to enter a completely new set of details.

Yes No

* Building number or name

* Street

District

* City or town

County or administrative area

* Postcode

* Country

* Does a premises licence or club premises certificate have effect in relation to the premises (or any part of the premises)?

Neither Premises licence Club premises certificate

* Premises licence number

Location Details

* Provide further details about the location of the event

This event is at the business premises related to HURK Limited, HWK (coffee shop) and HWK Bar, both of which share the same physical address and premises license, 29 White Post Lane and both share an open court yard and smoking area to

Continued from previous page...

the rear which is enclosed from the street. Details of ingress and egress to both be specified further down in the application.

If you intend to use only part of the premises at this address or intend to restrict the area to which this notice applies, give a description and details below ([see also guidance on completing the form, note 3](#))

The whole address of the business will be used: both the coffee shop and HWK Bar, along with its court yard to the rear.

Describe the nature of the premises below ([see also guidance on completing the form, note 4](#))

HWK Bar is a licensed small cocktail and wine bar, which accommodates seating and standing with DJs on the weekend during licensed hours. During this particular weekend the activities will be the same, except we wish to extend the hours of the premises for Halloween weekend. HWK coffee will also be used to accommodate extra space for the "event" / weekend's proposed extended hours. There is also a courtyard to the rear of both the coffee shop and the cocktail / wine bar, which is enclosed from the road. This area also has a bar area with additional outdoor heating and also acts as the smoking area.

The whole premises is a versatile and unique space and although only recently open, has attracted a regular, diverse and discerning clientele with interests in the higher end aspects of music, art, drinking and dining, as is reflected in the array of cocktails, wine and drinks; and music on offer from our DJs.

Describe the nature of the event below ([see also guidance on completing the form, note 5](#))

We intend to mark out the calendar with several dates, where we would like to celebrate the establishment beyond our regular licensing hours. With our well planned out noise management plan; "Polite Solution Ltd" security (who also manage security for neighbouring venues Crate, The Yard, Mick's Garage, Beer Merchants Tap and Bloc); our experience and clientele, we feel confident in doing so with no issues. This TEN is for Halloween. There will be a little bit more promotion than usual: a facebook event, special guest DJs and later finish. We will also be utilising our adjacent coffee shop.

Section 4 of 9

LICENSABLE ACTIVITIES

State the licensable activities that you intend to carry on at the premises ([see also guidance on completing the form, note 6](#)):

- The sale by retail of alcohol
- The supply of alcohol by or on behalf of a club to, or to the order of, a member of the club
- The provision of regulated entertainment
- The provision of late night refreshment
- The giving of a late temporary event notice

([See also guidance on completing the form, note 7](#)).

Late notices can be given no later than 5 working days but no earlier than 9 working days before the event.

([See also guidance on completing the form, note 8](#)).

Event Dates

There must be a period of at least 10 working days between the date you submit this form and the date of the earliest event when you will be using these premises for licensable activities.

State the dates on which you intend to use these premises for licensable activities

Continued from previous page...

(see also guidance on completing the form, note 9)

Event start date / /
dd mm yyyy

The maximum period for using premises for licensable activities under the authority of a temporary event notice is 168 hours or seven days.

Event end date / /
dd mm yyyy

State the times during the event period that you propose to carry on licensable activities (give times in 24 hour clock)

(see also guidance on completing the form, note 10)

State the maximum number of people at any one time that you intend to allow to be present at the premises during the times when you intend to carry on licensable activities, including any staff, organisers or performers

Note that the maximum number of people cannot exceed 499.

(see also guidance on completing the form, note 11)

If the licensable activities will include the supply of alcohol, state whether the supplies will be for consumption on or off the premises, or both

(see also guidance on completing the form, note 12):

- On the premises only
- Off the premises only
- Both

Section 5 of 9

RELEVANT ENTERTAINMENT (See also guidance on completing the form, note 13)

State if the licensable activities will include the provision of relevant entertainment. If so, state the times during the event period that you propose to provide relevant entertainment

DJs will be playing recorded music on the Friday from 7pm (normal start time for the resident DJs) until 2am (finish time on this TEN for the Friday); then from 6pm - 4am in HWK Bar on the Saturday night / Sunday morning and 9pm - 1am in HWK coffee shop on the Saturday night / Sunday morning.

The sounds will be restricted (as in accordance with our submitted sound management plan), due to the nature of the ingress and egress of the premises; black wool serge drape just in front of the gated entrance to the premises (main entrance for everybody on the day and night); double glazed windows across the front of the coffee shop and bar (along with black wool serge acting as curtains); there will also be an additional black wool serge curtain just after the exit doors from HWL bar to the courtyard. Please see attached sound management plan docs in e-mail to all relevant authorities (including sketched layout).

There will also be signage at the exit requesting guests be quiet on leaving in to taxis or walking home. The security on the exit door will also emphasise this to guests on them leaving. To manage the flow of people and further mitigate against any noise disturbance, the middle, gated entrance will be the only formal entrance for guests to the premises. From there,

Continued from previous page...

guests can access the courtyard directly, HWK bar on the right and the coffee shop from it's rear. The coffee shop door to the street will remain permanently closed, which will mitigate against any noise issues from that space. Exiting the premises will solely be from HWK Bar's door entrance to the street. This will also mean that the door isn't constantly opening and closing allowing noise to escape, if there was no ingress and egress plan and guests could use the HWK bar door to enter and leave. This also ensures one way traffic throughout the whole venue.

The entrance and exit to each space will be manned by security: 1 at the coffee shop rear entrance (it's only access point on the night); one at the main entrance to the premises (the gated entrance with door in the gate) and 1 at HWK's door to the street, which will be opened by the security when people leave. All security will also be able to navigate guests to the toilet and smoking area, ensuring guests aren't going out on the street to loiter and smoke. Due to the courtyard this can all be contained and managed, further reducing the capability to disturb neighbours close by during the event.

It also must be pointed out, that in the event of an emergency, there are two doors on to the street (one from HWK Bar and one from the coffee shop) and the gated main entrance can be full opened and is 3 metres wide.

Section 6 of 9

PERSONAL LICENCE HOLDERS [\(See also guidance on completing the form, note 14\)](#)

Do you currently hold a valid personal licence? Yes No

Provide the details of your personal licence below.

Issuing licensing authority

Licence number

Date of issue / /
dd mm yyyy

Any further relevant details

Section 7 of 9

PREVIOUS TEMPORARY EVENT NOTICES [\(See also guidance on completing the form, note 15\)](#)

Have you previously given a temporary event notice in respect of any premises for events falling in the same calendar year as the event for which you are now giving this temporary event notice? Yes No

Continued from previous page...

Have you already given a temporary event notice for the same premises in which the event period:

- a) Ends 24 hours or less before; or Yes No
- b) Begins 24 hours or less after the event period proposed in this notice?

Section 8 of 9

ASSOCIATES AND BUSINESS COLLEAGUES [\(See also guidance on completing the form, note 16\)](#)

Has any associate of yours given a temporary event notice for an event in the same calendar year as the event for which you are now giving a temporary event notice?

- Yes No

Has any associate of yours already given a temporary event notice for the same premises in which the event period:

- a) Ends 24 hours or less before; or Yes No
- b) Begins 24 hours or less after the event period proposed in this notice?

Has any person with whom you are in business carrying on licensable activities given a temporary event notice for an event in the same calendar year as the event for which you are now giving a temporary event notice?

- Yes No

Has any person with whom you are in business carrying on licensable activities already given a temporary event notice for the same premises in which the event period:

- a) Ends 24 hours or less before; or Yes No
- b) Begins 24 hours or less after the event period proposed in this notice?

Continued from previous page...

Section 9 of 9

CONDITION [\(See also guidance on completing the form, note 18\)](#)

It is a condition of this temporary event notice that where the relevant licensable activities described in Sections 4 and 5 above include the supply of alcohol that all such supplies are made by or under the authority of the premises user.

PAYMENT DETAILS

This fee must be paid to the authority. If you complete the application online, you must pay it by debit or credit card.
This formality requires a fixed fee of £21

DECLARATION [\(See also guidance on completing the form, note 19\)](#)

(i) to knowingly or recklessly make a false statement in connection with this temporary event notice and that a person is liable on summary conviction for such an offence to a fine of any amount; and (ii) to permit an unauthorised licensable activity to be carried on at any place and that a person is liable on summary conviction for any such offence to a fine of any amount, or to imprisonment for a term not exceeding six (6) months, or to both.

* For completion by the Licensing Authority
* I acknowledge receipt of this temporary event notice
* SIGNATURE _____ On behalf of the Licensing Authority NAME OF OFFICER _____
DATE _____

* Ticking this box indicates you have read and understood the above declaration

This section should be completed by the applicant, unless you answered "Yes" to the question "Are you an agent acting on behalf of the applicant?"

* Full name
* Capacity
* Date / /
 dd mm yyyy

Once you're finished you need to do the following:
1. Save this form to your computer by clicking file/save as..
2. Go back to <https://www.gov.uk/apply-for-a-licence/temporary-event-notice/tower-hamlets/apply-1> to upload this file and continue with your application.
Don't forget to make sure you have all your supporting documentation to hand.

OFFICE USE ONLY

Applicant reference number	<input type="text"/>
Fee paid	<input type="text"/>
Payment provider reference	<input type="text"/>
ELMS Payment Reference	<input type="text"/>
Payment status	<input type="text"/>
Payment authorisation code	<input type="text"/>
Payment authorisation date	<input type="text"/>
Date and time submitted	<input type="text"/>
Approval deadline	<input type="text"/>
Error message	<input type="text"/>
Is Digitally signed	<input type="checkbox"/>

[1](#) [2](#) [3](#) [4](#) [5](#) [6](#) [7](#) [8](#) [9](#) [Next >](#)

Appendix 2



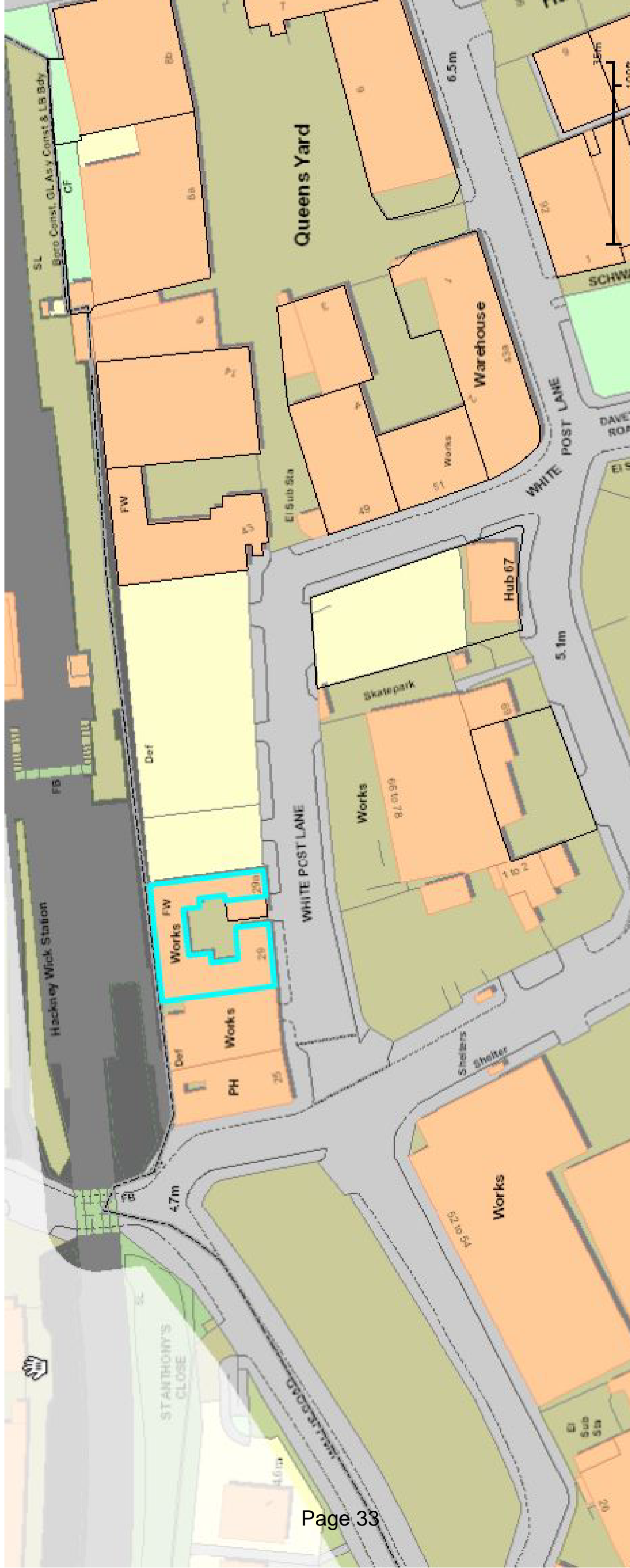

Appendix 3

(Hurk Limited)
Unit 8 29 White Post Lane
London
E9 5EN

Licensable Activities authorised by the licence

The sale by retail of alcohol
The provision of regulated entertainment consisting of Plays &
Recorded Music

See the attached licence for the licence conditions

Signed by

David Tolley
Head of Trading Standards &
Environmental Health

Date: 13th June 2019



TOWER HAMLETS

LICENSING ACT 2003

Part A - Format of premises licence

Premises licence number

29059

Part 1 - Premises details

Postal address of premises, or if none, ordnance survey map reference or description

Unit 8 29 White Post Lane

Post town

London

Post code

E9 5EN

Telephone number

Where the licence is time limited the dates

N/A

Licensable activities authorised by the licence

The sale by retail of alcohol

The provision of regulated entertainment (**consisting of Plays & Recorded Music**)

The times the licence authorises the carrying out of licensable activities

Supply of alcohol (Indoors & Outdoors)

Monday to Thursday from 11:30 hours to 23:30 hours

Friday to Saturday from 11:30 hours to 00:00 hours

Sunday from 11:30 hours to 22:30 hours

Non-standard timings

Until 01:30 on the evening preceding a Bank Holiday. Until 4am on New Years Eve, until 01:30 on New Year's Day.

Regulated Entertainment Plays & Recorded Music (Indoors & Outdoors)

Monday to Thursday from 11:30 hours to 23:30 hours

Friday to Saturday from 11:30 hours to 00:00 hours

Sunday from 11:30 hours to 22:30 hours

Non-standard timings

Until 01:30 on the evening preceding a Bank Holiday. Until 4am on New Years Eve, until 01:30 on New Year's Day.

The opening hours of the premises

Hours premises are open to the public

Monday to Thursday from 11:30 hours to 23:00 hours

Friday to Saturday from 11:30 to 23:30 hours

Sunday from 11:30 to 22:00 hours

Non-standard timings

Until 01:30 on the evening preceding a Bank Holiday. Until 4am on New Year's Eve, until 01:30 on New Year's Day.

Where the licence authorises supplies of alcohol whether these are on and/ or off supplies

On and off sales

Part 2

Name, (registered) address, telephone number and email (where relevant) of holder of premises licence

Carl Edlund & Patrick Lindblom(Company Director)

Unit R3 55 Wallis Road

London

E9 5LH

Telephone Number: [REDACTED]

Email address: [REDACTED]

Registered number of holder, for example company number, charity number (where applicable)

Registered Company number: 11889653

Name, address and telephone number of designated premises supervisor where the premises licence authorises the supply of alcohol

Carl Edlund

[REDACTED]

[REDACTED]

[REDACTED]

Personal licence number and issuing authority of personal licence held by designated premises supervisor where the premises licence authorises for the supply of alcohol

Personal licence: 101165

Issuing Authority: London Borough of Hackney Council

Annex 1 - Mandatory conditions

No supply of alcohol may be made under the premises licence-

- a) at a time where there is no designated premises supervisor in respect of the premises licence, or
- b) at a time when the designated premises supervisor does not hold a personal licence or his personal licence is suspended

1.

- (1) The responsible person must ensure that staff on relevant premises do not carry out, arrange or participate in any irresponsible promotions in relation to the premises
- (2) In this paragraph, an irresponsible promotion means any one or more of the following activities, or substantially similar activities, carried on for the purpose of encouraging the sale or supply of alcohol for consumption on the premises;
 - (a) games or other activities which require or encourage, or are designed to require or encourage, individuals to—
 - (i) drink a quantity of alcohol within a time limit (other than to drink alcohol sold or supplied on the premises before the cessation of the period in which the responsible person is authorised to sell or supply alcohol), or
 - (ii) drink as much alcohol as possible (whether within a time limit or otherwise);
 - (b) provision of unlimited or unspecified quantities of alcohol free or for a fixed or discounted fee to the public or to a group defined by a particular characteristic in a manner which carries a significant risk of undermining a licensing objective
 - (c) provision of free or discounted alcohol or any other thing as a prize to encourage or reward the purchase and consumption of alcohol over a period of 24 hours or less in a manner which carries a significant risk of undermining a licensing objective;
 - (d) selling or supplying alcohol in association with promotional posters or flyers on, or in the vicinity of, the premises which can reasonably be considered to condone, encourage or glamorise anti-social behaviour or to refer to the effects of drunkenness in any favourable manner;
 - (e) dispensing alcohol directly by one person into the mouth of another (other than where that other person is unable to drink without assistance by reason of disability)

2. The responsible person must ensure that free potable water is provided on request to customers where it is reasonably available.

3.

- (1) The premises licence holder or club premises certificate holder must ensure that an age verification policy is adopted in respect of the premises in relation to the sale or supply of alcohol.
 - (2) The designated premises supervisor in relation to the premises licence must ensure that the supply of alcohol at the premises is carried on in accordance with the age verification policy
 - (3) The policy must require individuals who appear to the responsible person to be under 18 years of age (or such older age as may be specified in the policy) to produce on request, before being served alcohol, identification bearing their photograph, date of birth and either—
 - (a) a holographic mark, or
 - (b) an ultraviolet feature.
4. The responsible person must ensure that—
- (a) where any of the following alcoholic drinks is sold or supplied for consumption on the premises (other than alcoholic drinks sold or supplied having been made up in advance ready for sale or supply in a securely closed container) it is available to customers in the following measures—
 - (i) beer or cider: ½ pint
 - (ii) gin, rum, vodka or whisky: 25 ml or 35 ml; and
 - (iii) still wine in a glass: 125 ml;
 - (b) these measures are displayed in a menu, price list or other printed material which is available to customers on the premises; and
 - (c) where a customer does not in relation to a sale of alcohol specify the quantity of alcohol to be sold, the customer is made aware that these measures are available.
5. 1. A relevant person shall ensure that no alcohol is sold or supplied for consumption on or off the premises for a price which is less than the permitted price.
2. For the purposes of the condition set out in paragraph 1—
- (a) “duty” is to be construed in accordance with the Alcoholic Liquor Duties Act 1979;
 - (b) “permitted price” is the price found by applying the formula —

$$P = D + (D \times V)$$
 where —
 - (i) **P** is the permitted price
 - (ii) **D** is the amount of duty chargeable in relation to the alcohol as if the duty were charged on the date of the sale or supply of the alcohol, and

- (iii) **V** is the rate of value added tax chargeable in relation to the alcohol as if the value added tax were charged on the date of the sale or supply of the alcohol;
 - (c) “relevant person” means, in relation to premises in respect of which there is in force a premises licence
 - (i) the holder of the premises licence
 - (ii) the designated premises supervisor (if any) in respect of such a licence, or
 - (iii) the personal licence holder who makes or authorises a supply of alcohol under such a licence
 - (d) “relevant person” means, in relation to premises in respect of which there is in force a club premises certificate, any member or officer of the club present on the premises in a capacity which enables the member or officer to prevent the supply in question; and
 - (e) “value added tax” means value added tax charged in accordance with the Value Added Tax Act 1994
3. Where the permitted price given by Paragraph (b) of paragraph 2 would (apart from this paragraph) not be a whole number of pennies, the price given by that sub-paragraph shall be taken to be the price actually given by that sub-paragraph rounded up to the nearest penny.
4. (1) Sub-paragraph (2) applies where the permitted price given by Paragraph (b) of paragraph 2 on a day (“the first day”) would be different from the permitted price on the next day (“the second day”) as a result of a change to the rate of duty or value added tax
- (2) The permitted price which would apply on the first day applies to sales or supplies of alcohol which take place before the expiry of the period of 14 days beginning on the second day

For “OFF SALES ONLY” Add the following conds...

- 3.
- (1) The premises licence holder or club premises certificate holder must ensure that an age verification policy is adopted in respect of the premises in relation to the sale or supply of alcohol.
 - (2) The designated premises supervisor in relation to the premises licence must ensure that the supply of alcohol at the premises is carried on in accordance with the age verification policy
 - (3) The policy must require individuals who appear to the responsible person to be under 18 years of age (or such older age as may be specified in the policy) to produce on request, before being served alcohol, identification bearing their photograph, date of birth and either—

- (a) a holographic mark, or
 - (b) an ultraviolet feature.
5. 1. A relevant person shall ensure that no alcohol is sold or supplied for consumption on or off the premises for a price which is less than the permitted price.
2. For the purposes of the condition set out in paragraph 1—
- (a) “duty” is to be construed in accordance with the Alcoholic Liquor Duties Act 1979;
 - (b) “permitted price” is the price found by applying the formula —

$$P = D + (D \times V)$$
 where —
 - (i) **P** is the permitted price
 - (ii) **D** is the amount of duty chargeable in relation to the alcohol as if the duty were charged on the date of the sale or supply of the alcohol, and
 - (iii) **V** is the rate of value added tax chargeable in relation to the alcohol as if the value added tax were charged on the date of the sale or supply of the alcohol;
 - (c) “relevant person” means, in relation to premises in respect of which there is in force a premises licence
 - (i) the holder of the premises licence
 - (ii) the designated premises supervisor (if any) in respect of such a licence, or
 - (iii) the personal licence holder who makes or authorises a supply of alcohol under such a licence
 - (d) “relevant person” means, in relation to premises in respect of which there is in force a club premises certificate, any member or officer of the club present on the premises in a capacity which enables the member prevent the supply in question; and
 - (e) “value added tax” means value added tax charged in accordance with the Value Added Tax Act 1994
3. Where the permitted price given by Paragraph (b) of paragraph 2 would (apart from this paragraph) not be a whole number of pennies, the price given by that sub-paragraph shall be taken to be the price actually given by that sub-paragraph rounded up to the nearest penny.
4. (1) Sub-paragraph (2) applies where the permitted price given by Paragraph (b) of paragraph 2 on a day (“the first day”) would be

different from the permitted price on the next day (“the second day”) as a result of a change to the rate of duty or value added tax

- (2) The permitted price which would apply on the first day applies to sales or supplies of alcohol which take place before the expiry of the period of 14 days beginning on the second day

Where a premises licence includes a condition that at specified times one or more individuals must be at the premises to carry out a security activity, such individuals must be licensed with the Security Industry Authority. This does not apply to premises within paragraph 8(3) (a) of Schedule 2 to the Private Security Industry Act 2001, (premises with premises licences authorising plays or films), or in respect of premises in relation to- any occasion mentioned in paragraph 8(3)(b) or (c) of Schedule 2 (premises being used exclusively by club with club premises certificate, under a temporary event notice authorising plays or films or under a gaming licence), or any occasion within paragraph 8(3)(d) of Schedule 2 (occasions prescribed by regulations under that Act) unless the Licence specifically states otherwise.

Security activity means an activity to which paragraph 2(1)(a) of Schedule 2 of the Private Security Industry Act 2001 of that schedule applies, and Paragraph 8(5) of Schedule 2 (interpreting of references to an occasion) applies as it applies in relation to paragraph 8 of Schedule 2 of the Private Security Industry Act 2001

Annex 2 - Conditions consistent with the operating Schedule

1. The premises shall install and maintain a comprehensive CCTV system as per the minimum requirements of the Tower Hamlets Police Licensing Team. All entry and exit points will be covered enabling frontal identification of every person entering in any light condition. The CCTV system shall continually record whilst the premises is open for licensable activities and during all times when customers remain on the premises. All recordings shall be stored for a minimum period of 30 days with date and time stamping. Viewing of recordings shall be made available immediately upon the request of Police or authorised officer throughout the entire 30 day period.
2. All staff responsible for selling alcohol shall receive regular training in the Licensing Act 2003 in terms of the licensing objectives, offences committed under the Act and conditions of the Premises Licence. Written records of this training shall be retained and made available to police and authorised officers of the Licensing Authority on request.

3. An incident log shall be kept at the premises, and made available on request to an authorised officer of the Council or the Police, which will record the following:
 - a) All crimes reported to the venue;
 - b) Any complaints received;
 - c) Any incidents of disorder;
 - e) Any refusal of the sale of alcohol;
 - h) Any visit by a relevant authority or emergency service.
4. Notices shall be prominently displayed at all exits requesting patrons to respect the needs of local residents and businesses and leave the area quietly.
5. Loudspeakers shall not be located in the entrance lobby or outside the premise building.
6. Refuse, including bottles are to be taken and placed into receptacles outside the premises at times which will minimise the disturbance to nearby premises. Refuse shall not be collected between the hours of 23:00 hours and 07:00 hours.
7. A Challenge 25 proof of age scheme shall be operated at the premises where the only acceptable forms of identification are recognised photographic identification cards, such as a driving licence, passport or proof of age card with the PASS Hologram.
8. A record shall be kept detailing all refused sales of alcohol. The record should include the date and time of the refused sale and the name of the member of staff who refused the sale. The record shall be available for inspection at the premises by the police or an authorised officer at all times whilst the premises are open.
9. All windows and external doors shall be kept closed when regulated entertainment takes place, except for the immediate access & egress of persons.
10. No collections of waste or recycling materials (including bottles) from the premises shall take place between 22:00 hours and 08:00 hours on the following day.
11. No deliveries to the premises shall take place between 22:00 hours and 08:00 hours the following day.

12. No external use of the courtyard area after 21:00 hours, except patrons permitted to temporarily leave and then re-enter the premises, e.g. to smoke, which shall be limited to 8 persons, after 21:00 hours.

13. Access via the under passage shall be permitted until 23:30 hours.

Annex 3 - Conditions attached after a hearing by the licensing authority

Not applicable

Annex 4 - Plans

The plans are those submitted to the licensing authority on the following date:

2017 (enter date and if relevant plan No. and area covered within the plans.)

Plan 1- ground floor

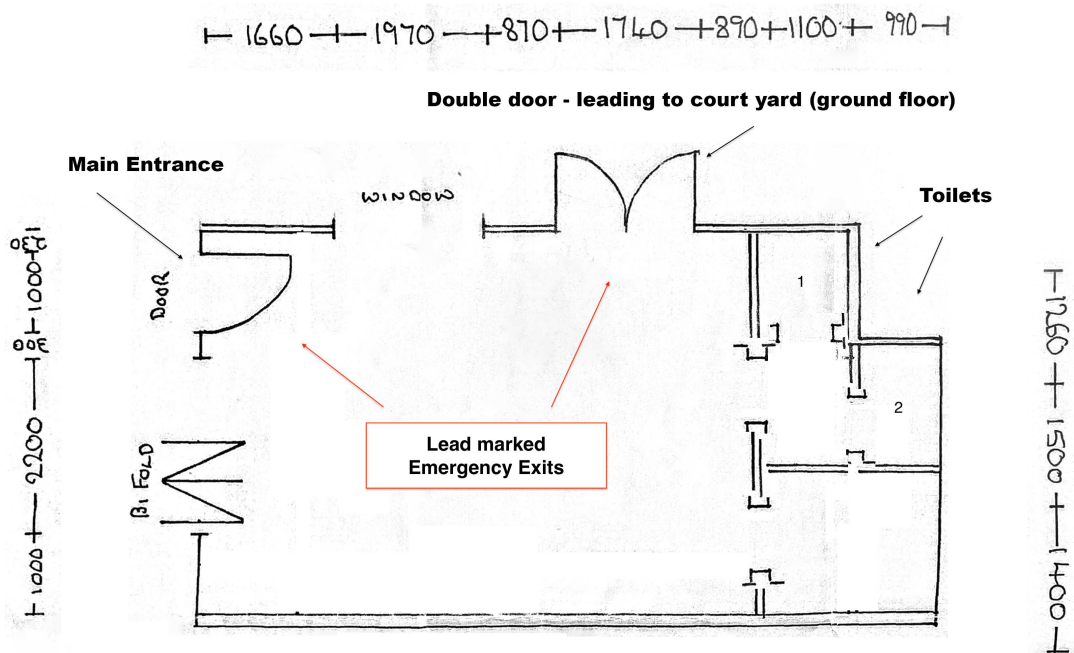

UNIT 8
41.80 SQUARE METERS
450 SQUARE FOOT.

**29 White Post Lane
London
E9 5EN**

Plan 2 – outside courtyard area





Part B - Premises licence summary

Premises licence number

29059

Premises details

Postal address of premises, or if none, ordnance survey map reference or description

Unit 8 29 White Post Lane

Post town

London

Post code

E9 5EN

Telephone number

07787181457

Where the licence is time limited the dates

N/A

Licensable activities authorised by the licence

The sale by retail of alcohol
The provision of regulated entertainment consisting of Plays & Recorded Music

The times the licence authorises the carrying out of licensable activities

Supply of alcohol

Monday to Thursday from 11:30 hours to 23:30 hours
Friday to Saturday from 11:30 hours to 00:00 hours
Sunday from 11:30 hours to 22:30 hours

Non-standard timings

Until 01:30 on the evening preceding a Bank Holiday. Until 4am on New Years Eve, until 01:30 on New Years Day.

Regulated Entertainment (Plays & Recorded Music)

Monday to Thursday from 11:30 hours to 23:30 hours
Friday to Saturday from 11:30 hours to 00:00 hours
Sunday from 11:30 hours to 22:30 hours

Non-standard timings

Until 01:30 on the evening preceding a Bank Holiday. Until 4am on New Years Eve, until 01:30 on New Years Day

The opening hours of the premises

Hours premises are open to the public

Monday to Thursday from 11:30 hours to 23:00 hours
Friday to Saturday from 11:30 to 23:30 hours
Sunday from 11:30 to 22:00 hours

Non-standard timings

Until 01:30 on the evening preceding a Bank Holiday. Until 4am on New Years Eve, until 01:30 on New Years Day.

Name, (registered) address of holder of premises licence

Carl Edlund & Patrick
Lindblom(Company Director)
Unit R3 55 Wallis Road
London
E9 5LH

Where the licence authorises supplies of alcohol whether these are on and / or off supplies

On and off sales

Registered number of holder, for example company number, charity number (where applicable)

Registered Company number: 11889653

Name of designated premises supervisor where the premises licence authorises for the supply of alcohol

Carl Edlund

State whether access to the premises by children is restricted or prohibited

No restrictions

Appendix 4

Kathy Driver

From: Nicola Cadzow
Sent: 21 October 2019 10:42
To: Licensing
Cc: [REDACTED]
Subject: MAU REPRESENTATION 123051 Hurk Limited Unit 8 29 White Post Lane

Follow Up Flag: Follow up
Flag Status: Flagged

Dear Licensing,

I have considered the Temporary Event Notice (TENs) application for Hurk Limited Unit 8 29 White Post Lane and the potential impact of public nuisance and measures to prevent noise generated from within the premises or outside it which could cause disturbance to people in the vicinity.

The applicant is proposing the hours for their TENs application for the premises for licensable activities: sale of alcohol and the regulated entertainment on:

Saturday 2nd November 2019 until 02:00 hours (some two hours extension on current licence hours)

Sunday 3rd November 2019 until 04:00 hours (some five and a half hours extension on current licence hours)

Sensitive premises: Residential commercial premises in close proximity approximately 10 meters away.

In my view the TENs application, as it stands fails, to comply with the objective of the Licensing Act 2003 relating to “public nuisance” for the following reasons:-

- Noise breakout from the venue affecting neighbouring residents.
- Access & egress to and from the venue, of patrons, especially due to patrons likely to be in high spirits; and
- The hours of operation (inclusive of proposals)

CONCLUSION

Environmental Protection **does not** support the TENs application for Hurk Limited Unit 8 29 White Post Lane as there is greater likelihood of disturbance to residential premises at the noise sensitive hours sought.

Kind regards

Nicola Cadzow
Environmental Protection
Environmental Health Technical Officer
Place Directorate
Public Realm, Environmental Health & Trading Standards
London Borough of Tower Hamlets, John Onlsow House, 1 Ewart Place, London E3 5EQ

This page is intentionally left blank